



AutomationDirect.com™

Direct Logic 205

Smart Distributed System CPU

F2-SDS-1

TRADEMARKS

™AutomationDirect.com is a Trademark of AutomationDirect.com

COPYRIGHT

Copyright 1994, FACTS Engineering Inc., 8049 Photonics Dr., New Port Richey, Florida, 34655.. World rights reserved. No part of this publication may be stored in a retrieval system, transmitted, or reproduced in any way, including but not limited to photocopy photograph, magnetic or other recording media, without the prior agreement and written permission of FACTS Engineering, Inc.

Last Issued Date: September 1997
Current Issued Date: June 1999

WARNING

Thank you for purchasing automation equipment from FACTS Engineering. We want your new FACTS Engineering automation equipment to operate safely. Anyone who installs or uses this equipment should read this publication (and any other relevant publications) before installing or operating the equipment.

To minimize the risk of potential safety problems, you should follow all applicable local and national codes that regulate the installation and operation of your equipment. These codes vary from area to area and usually change with time. It is your responsibility to determine which codes should be followed, and to verify that the equipment, installation, and operation is in compliance with the latest revision of these codes.

At a minimum, you should follow all applicable sections of the National Fire Code, National Electrical Code, and the codes of the National Electrical Manufacturers Association (NEMA). There may be local regulatory or government offices that can help determine which codes and standards are necessary for safe installation and operation.

Equipment damage or serious injury to personnel can result from the failure to follow all applicable codes and standards. We do not guarantee the products described in this publication are suitable for your particular application, nor do we assume any responsibility for your product design, installation, or operation.

If you have any questions concerning the installation or operation of this equipment, or if you need additional information, please call us at 1-800-783-3225.

This document is based on information available at the time of its publication. While efforts have been made to be accurate, the information contained herein does not purport to cover all details or variations in hardware and software, nor to provide for every possible contingency in connection with installation, operation, and maintenance. Features may be described herein which are not present in all hardware and software systems. FACTS Engineering assumes no obligation of notice to holders of this document with respect to changes subsequently made. FACTS Engineering retains the right to make changes to hardware and software at any time, without notice. FACTS Engineering makes no representation or warranty, expressed, implied, or statutory with respect to, and assumes no responsibility for the accuracy, completeness, sufficiency, or usefulness of the information contained herein. No warranties of merchantability of fitness for purpose shall apply.

TABLE OF CONTENTS

CHAPTER 1 : INTRODUCTION	1.1
SDS NETWORK FEATURES	1.1
APPLICATIONS	1.1
SDS PROTOCOL FEATURES	1.2
Identification Data	1.2
Diagnostic Data	1.3
Operational Parameters	1.3
Actions	1.4
Events	1.4
205 CPU SDS Network Slave Specifications, F2-SDS-1	1.5
LED Indicators	1.6
CHAPTER 2 : PORT CONNECTIONS AND NETWORK WIRING	2.1
SDS NETWORK CONNECTIONS	2.1
SDS BUS CONNECTION	2.2
CHAPTER 3 : I/O CONFIGURATION	3.1
I/O BASES	3.1
I/O MODULES SUPPORTED	3.1
Discrete Module Types	3.2
Analog Module Types	3.2
I/O ADDRESSING	3.2

CHAPTER 1 : INTRODUCTION

The 205 CPU Network Slave, F2-SDS-1, is the interface between a Smart Distributed System and the DirectLogic 205 Industrial I/O.

The 205 CPU Smart Distributed System (SDS) Network Slave maps discrete and analog input and output modules directly into SDS Addresses.

SDS NETWORK FEATURES

The features of the SDS Network make it an ideal intelligent device network for the factory floor and other rugged applications.

- ✓ Low cost four wire installation is easy to install and maintain. Brad Harrison quick-disconnects eliminate installation errors when adding a device.
- ✓ Power is integrated into device wiring.
- ✓ Low cost network hardware originally developed for automobile systems such as anti-lock brakes (CAN bus).
- ✓ High-Information network provides advanced diagnostics and features.
- ✓ Response times to .10 msec per device.
- ✓ Industrially rugged and highly noise immune differential data transmission.
- ✓ Advanced error management and nondestructive arbitration with undetected bit error rates near zero.

APPLICATIONS

A SDS Network is typically used in distributed I/O installations such as conveyors and other applications where field devices are not concentrated. It is also used when an application requires one of the unique features or the advanced diagnostics provided by of the SDS Network.

Other PLC Direct networking options for reducing wiring costs include Slice I/O (16 points per drop) and Remote I/O (128 points per drop).

SDS PROTOCOL FEATURES

The 205 SDS CPU contains a data base which consists of identification data, diagnostic information and parameters which control the operation of the 205 SDS CPU and I/O modules.

These features are summarized in the following table. The "ID" column is the SDS Component Modeling Specification Attribute ID assigned to each data base item.

The "Type" column indicates items which are Read Only (R), or are Read and Writable (R/W).

Attribute IDs 1, 3, 4, 7, and 11 through 15 are associated with the F2-SDS-1 CPU. These attributes exhibit an identical response from all addresses physically located in the CPU base. All other attribute IDs are associated with each individual address in the base.

Identification Data

ID	Item	Description	Type
0	NDD	Network Data Descriptor (number of inputs and outputs in each slot)	R
1	Baud Rate	Returns a single byte 0, indicating Autobaud Mode	R
2	Object Type	Location of 205 CPU in SDS Hierarchy	R
3	Vendor ID	Number assigned to the manufacture of the device	R
4	Device Address	List of SDS address for this physical device (1 address for each installed discrete I/O module plus 1 address per analog I/O point, range=1-126)	R/W
7	Firmware Version	Firmware revision level of F2-SDS-1 CPU	R
11	Serial Number	Manufacture's unique serial number	R
12	Date Code	Manufacture's date of manufacture code	R
13	Catalog Listing	Manufacture's order number	R
14	Vendor Name	Manufacture's name	R
15	Device Name	Manufacture's initial device description	R/W
56	Tag Name	Nick name assigned to the device by the user	R/W
57	Location	SDS address list corresponding to physical module location and analog channel	R

Diagnostic Data

ID	Item	Description	Type
8	Error Counter	Diagnostic Errors Counted	R
9	Error Register	Diagnostic Error flag register	R
53	Power Cycles	Number of power cycles the device has experienced	R/W

Operational Parameters

ID	Item	Description	Type
6	Un/Solicited Mode	Enable/Disable Change of Value messages	R/W
10	Cyclical Timer	Time between Input Status messages (Event 3)	R/W
18	Input Status	Discrete 4, 8, 12, or 16 bits Analog 12 bits, 12 bits plus sign, or 16 bits	R
19	Output Status	Discrete 4, 8, 12, or 16 bits Analog 12 bits	R/W
58	Watchdog Timer	Turns off outputs if bus communication is lost	R/W
61	Re-Transmission	Enables re-sending Change of Value if no ack	R/W
62	Change Value Mask	Enable/Disable Change State messages each I/O pt.	R/W
63	Deadband	Data change required to trigger an unsolicited analog input status message (Event 6)	R/W
64	Default Output	Data value assigned to analog output status following a watchdog timer time-out	R

Actions

#	Item	Description
0	NO-OP	Used during Autobaud at power-up.
1	Change Address	All three address change methods are supported. This allows devices with duplicate addresses to be easily changed.
2	Self Test	An Event 0 is sent if the Error Counter (ID=8) is non-zero.
6	Reset Errors	Clears the Error Counter (ID=8) and resets the flags in the Error Register (ID=9).
8	Enroll	Used to detect multiple devices with the same device address. Often used by host software packages in conjunction with Action 1.
51	Force I/O	Used to force Input Status, ID(18) or Output Status, ID(19) for either discrete or analog I/O.
52	Remove Force	Removes all forced states on all Input Status (ID=18) or Output Status (ID=34) or both inputs and outputs.
53	Data Descriptor	Used to determine the type of data any attribute requires or produces.

Events

#	Item	Description
0	Diagnostic Error	Sent if any of the error flags in the Error Register (ID=9) changes from 0 to 1.
3	End of Timer	Input Status (ID=18) is sent at the timer interval set by the Cyclical Timer (ID=10).
6	Change of Value	If an input changes value and the corresponding bit in the Change of State Mask (ID=62) is a 1 and Un/Solicited Mode (ID=6) is a 1 then Input Status (ID=18) is sent.
7	Watchdog Warning	This message is sent if the Watchdog Timer (ID=58) will expire within 20 msec and the timer is enabled (non-zero).

205 CPU SDS Network Slave Specifications, F2-SDS-1

Communication Rate	125K, 250K, 500K, 1M bps			
Maximum Distance	Rate	Devices	Trunk	Drop
	125K	64	1600'	24'
	250K	64	800'	12'
	500K	64	400'	6'
	1M	32	100'	3'
Protocol	SDS, Honeywell Micro Switch			
Error Detection	CRC error checking and other techniques provide for an undetected bit error rate near zero.			
Status Indication LEDs	PWR (green) RUN (green)			
Port	5 Pin			
Operating Environment	0oC to 60oC (32oF to 140oF) 5% to 95% humidity (non-condensing)			
Internal Power Consumption	160 mA maximum from +5V base supply			
I/O Configuration Range	4 to 128 Discrete Inputs 4 to 128 Discrete Outputs 4 to 64 Analog Inputs 2 to 16 Analog Outputs			

LED Indicators

The PWR LED illuminates when an external power source is connected to the isolation power supply in the base.

The RUN LED illuminates after the 205 Smart Distributed System CPU has completed all internal diagnostics.

The RUN LED will toggle once per second when the CPU is connected to an SDS network and is communicating with the SDS master. The "heart beat" of the RUN LED indicates that the 205 SDS CPU is on-line.

If the RUN LED stays on steady then the CPU is not connected to the SDS network (off-line).

There must be at least one I/O module installed in the base for the CPU to go on-line. If no modules are installed in the base then the RUN LED will toggle very rapidly (every .01 seconds).

If the RUN LED flashes rapidly (toggles every .1 second) then the power-up diagnostics performed by the CPU has failed. This is an indication of a fatal hardware problem in the system (defective I/O module, base, or CPU).

CHAPTER 2 : PORT CONNECTIONS AND NETWORK WIRING

The F2-SDS-1 CPU interfaces to the SDS Network with a European Style 5 position removable terminal block.

Typically the communications cable is connected to a terminal block in the control panel. The bus power supply and the cable to the F2-SDS-1 are connected to this terminal block. Please refer to the diagram on the following page.

SDS NETWORK CONNECTIONS

The 205 SDS CPU does not draw current from the bus +24V supply. However, a connection to the DC+ pin, pin 5, is required so that the SDS CPU can sense the presence of network bus power.

Pin Number	Description	Symbol
1	Shield	
2	Bus Communications (-) (White)	BUS -
3	Bus Communications (+) (Black)	BUS +
4	GND (Bus Power Common) (Blue)	
5	DC+ (Bus Power Positive) (Brown)	

SDS BUS CONNECTION

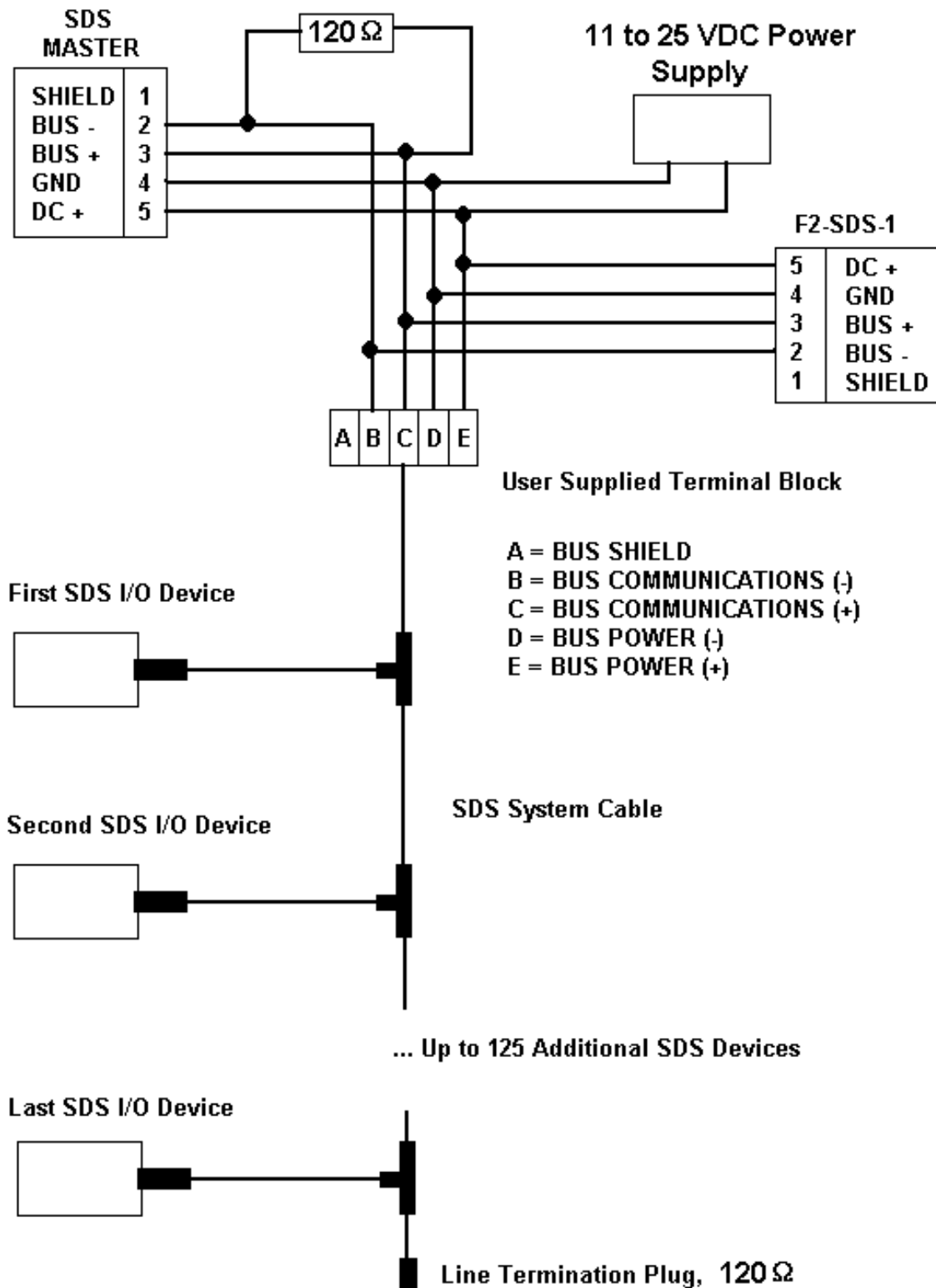

CHAPTER 3 : I/O CONFIGURATION

I/O BASES

The F2-SDS-1 CPU resides in the first slot of an I/O base. A single 205 SDS CPU supports up to eight I/O modules.

All I/O bases include an isolation power supply and have three, four, six, or nine slots. They are compatible with virtually all external power sources.

Bases which are compatible with an AC external power source also include a built-in 24 VDC user power supply typically used to power sensors and the field circuits of some I/O modules. The 24 VDC supply provides 200 ma.

Order Number	Number of I/O Modules	External Power Source
D2-03B	2	110 VAC or 220 VAC
D2-04B	3	110 VAC or 220 VAC
D2-06B	5	110 VAC or 220 VAC
D2-09B	8	110 VAC or 220 VAC
D2-03B-DC-1	2	12 VDC or 24 VDC
D2-04B-DC-1	3	12 VDC or 24 VDC
D2-06B-DC-1	5	12 VDC or 24 VDC
D2-09B-DC-1	8	12 VDC or 24 VDC
D2-03B-DC-2	2	125 VDC
D2-04B-DC-2	3	125 VDC
D2-06B-DC-2	5	125 VDC
D2-09B-DC-2	8	125 VDC

I/O MODULES SUPPORTED

There is a large selection of discrete and analog I/O modules to choose from when configuring a 205 SDS I/O system.

All 205 I/O modules can be distinguished by the module type. This is the number of I/O points, signal direction either input or output and signal type either discrete or analog. Some module types have several varieties. For example, there are presently two varieties of a four and eight channel, 12-bit analog input modules. There is one unit for 4-20 mA signals and another unit for universal voltage level signals. Varieties of discrete I/O modules include DC and AC signal types, sink and source signal directions plus other distinguishing features such as signal range, speed, power etc.

The 205 SDS CPU supports all varieties of the following types of I/O modules. Because we are constantly adding to our I/O range, please contact Automationdirect.com at 1-800-633-0405 for a sales catalog which will have a complete and up-to-date listing.

Discrete Module Types

- 4 Point Input
- 8 Point Input
- 16 Point Input
- 4 Point Output
- 8 Point Output
- 16 Point Output (includes 12 Point Output units)
- 4 Point Input/4 Point Output
- 8 Point Input/8 Point Output

Analog Module Types

The following analog modules are supported by the F2-SDS-1 module.

- 4 Channel Input (12-bit voltage or current)
- 8 Channel Input (12-bit voltage or current)
- 2 Channel Output (12-bit voltage or current)
- 4 Channel Input/2 Channel Output (12-bit current)
- 4 Channel Temperature Input (16-bit Thermocouple and RTD)

I/O ADDRESSING

The 205 SDS CPU assigns one SDS I/O address for each discrete I/O module and each analog channel installed in the base. Each discrete I/O module in the base uses one SDS I/O address regardless of the number of I/O points on the module. Each analog I/O module uses one SDS I/O address for each enabled analog channel. No addresses are assigned to unused analog channels. For example, an eight channel voltage analog input module, F2-08AD-2, jumpered for 5 channel operation, would be assigned 5 SDS I/O addresses.

Each discrete I/O module and analog point can be assigned any valid SDS address, 1-126. All addresses contained in the F2-SDS-1 are 126 by default (factory setting). A unique address for each discrete module and analog channel used must be assigned during installation. SDS addressing in the base does not need to be consecutive.